

# OS for Software Defined Vehicle

Qiyang Wang @ NIO

Sep 20, 2023





## Qiyang Wang

Global VP of Digital Systems at NIO, responsible for Digital Architecture, Software Platform, Connectivity & Cloud, Toolchain, Digital Integration & Testing

Prior to NIO, Co-founder & CTO of Retina Security, and engineering at Symantec and Exabeam

Ph.D in Computer Science from UIUC





## Agenda

- Introduction of NIO
- Software Defined Vehicle
- NIO Vehicle OS with seL4



# NIO - A Global Smart EV Company



50+ 33,000+

Office Locations

Employees



**NIO es8**



**NIO es6**



**NIO ec6**



333,410  
Cumulative Deliveries

**NIO et7**



**NIO es7**



**NIO et5**



June 1, 2023

# NIO Has 6,700+ Global Patents

定位装置和换电设备

CN201820502105.0

林海岩 | 李楠 | 田小涛 | 丁习坤 |  
刘俊 | 马永跃

电动汽车的自动换电站

CN201721454332.2

林海岩 | 马永跃 | 田小涛 | 丁习坤 |  
李楠

电动汽车  
小型自动充换电站

CN201620654048.9

刘洪涛 | 沈昊 | 魏文浩 | 朱浩 | 赖建文 |  
何旭 | 林海岩 | 李楠 |  
丁习坤 | 田小涛

Multiple core  
homologous battery module  
temperature monitoring system

102150070

车辆举升装置和换电平台

CN201820832127.3

林海岩 | 李楠 | 田小涛 | 丁习坤 |  
马永跃 | 刘俊

喷氨增热热泵空调  
系统和包括该系统的

吴伟 | 陆文海 | 张启宇 |  
加藤秀治

电动汽车的自动换

CN201721454333

林海岩 | 马永跃 | 田小涛 |  
李楠



Leading Battery System R&D  
and Industrial Capabilities

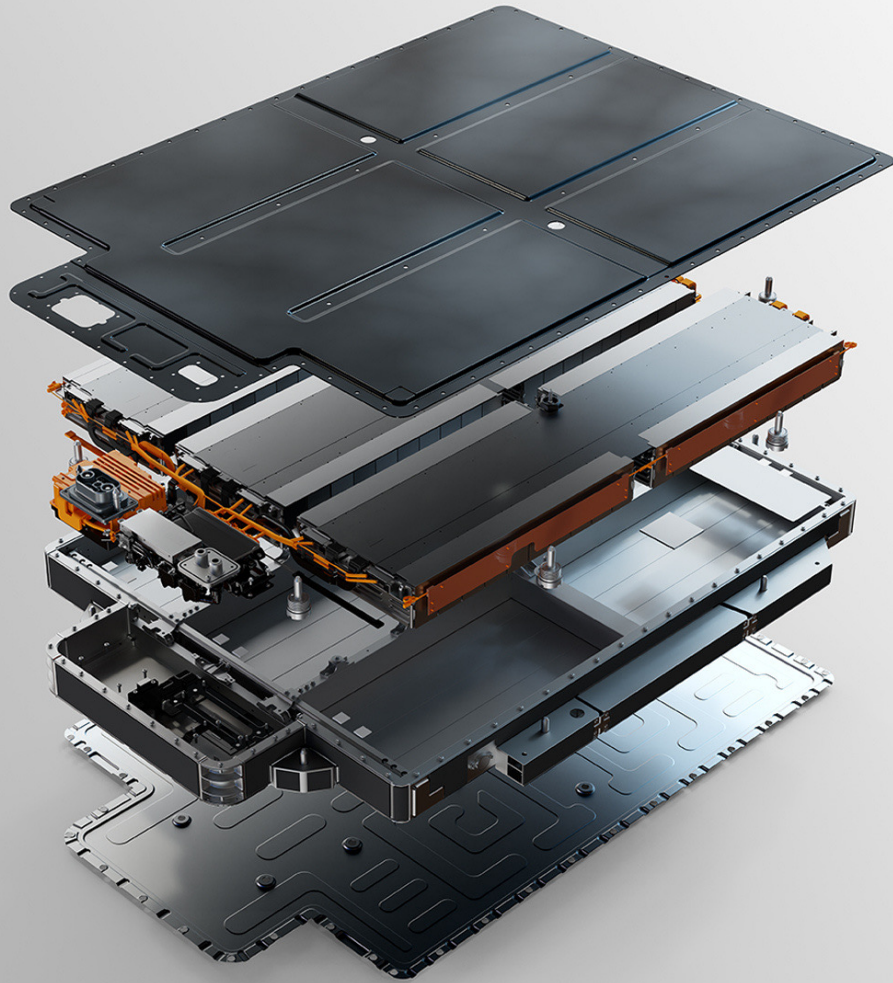

## High-Performing Electric Motors

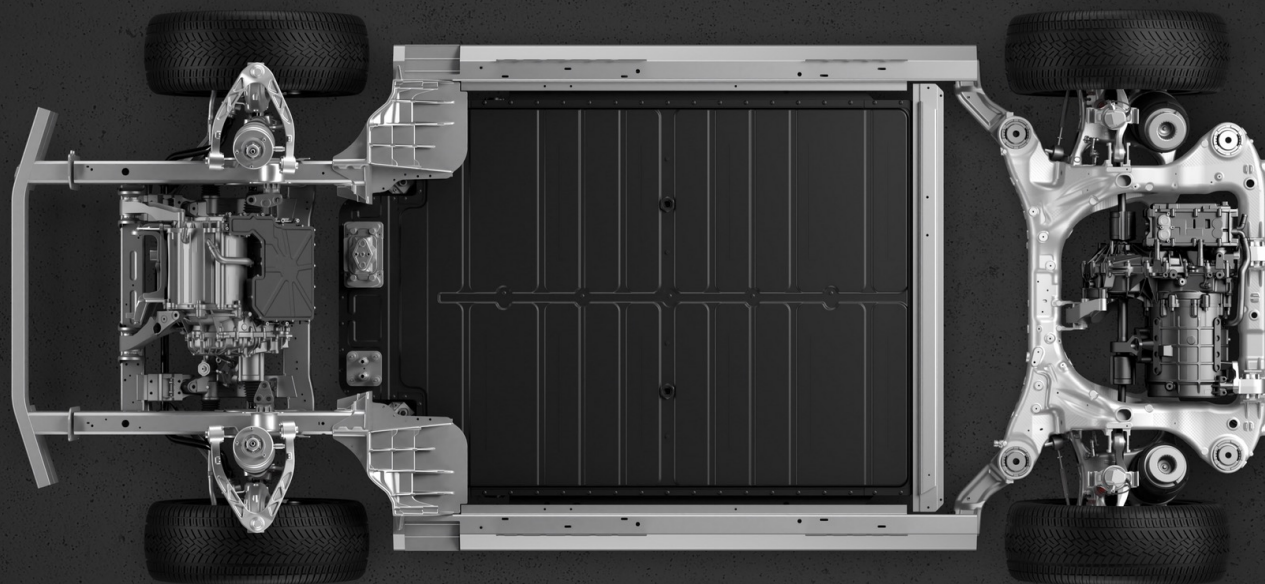



## Flexible Chassis Control

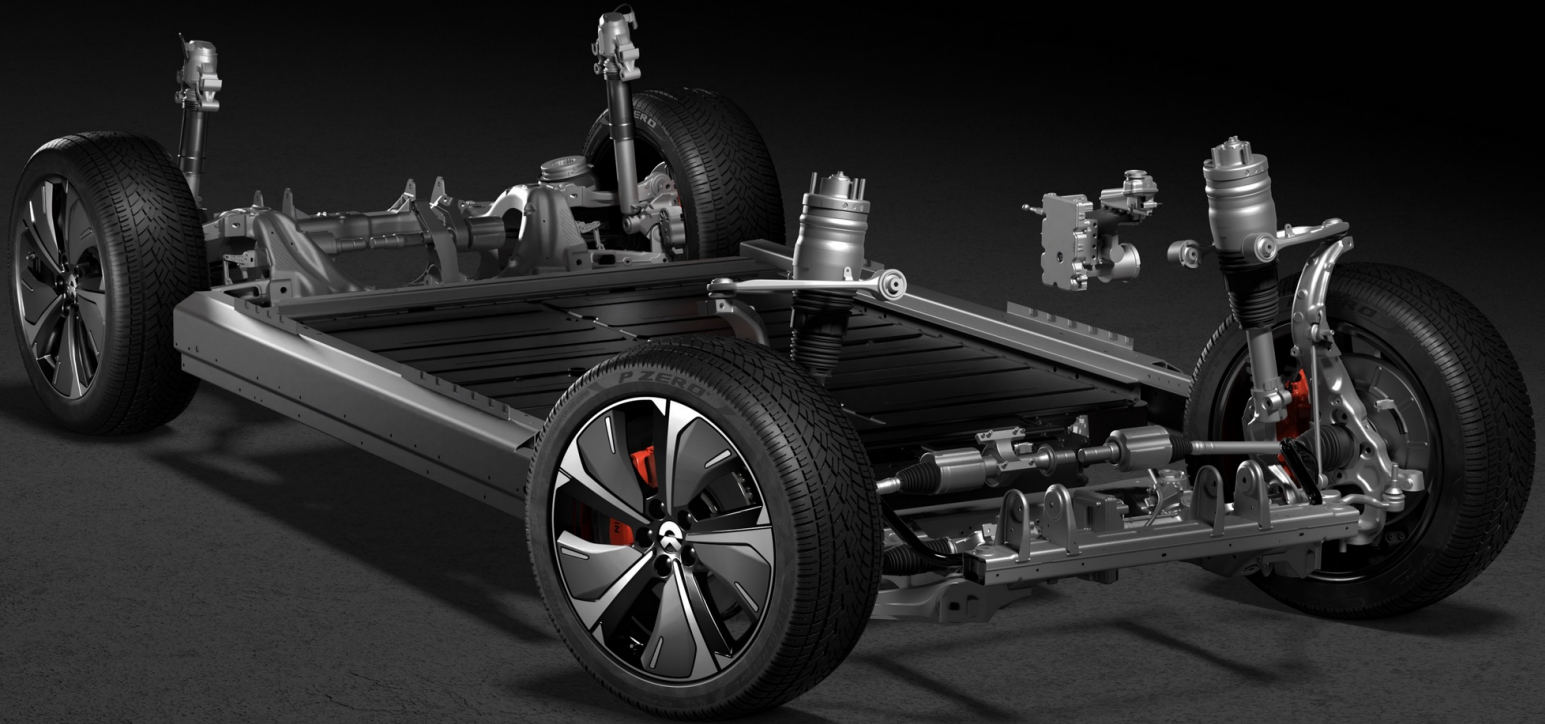



NIO Seat Platform



# Innovative Battery Swapping Technology

1,464+

Power Swap Stations

15,673

Charging Ports

69.5%

Residential Coverage

22M+

Cumulative Swaps

CHARGEABLE

SWAPPABLE

UPGRADABLE

June 1, 2023





# NIO Smart Systems

Smart Hardware

Computing Platform

Operating System

Smart Algorithms

Smart Applications



# PanoCinema

7.1.4 Surround Sound System  
23 Speakers  
1,000 W  
20 Channels

Advanced Algorithms  
Dolby ATMOS  
Dirac Pro

Premium Content  
Spotify  
Tidal

NIO

Immersive Mobile Living Space







N-Box  
AR Glasses



# Full Stack R&D for Autonomous Driving

Hardware  
OS  
Data  
Algorithm  
Toolchain

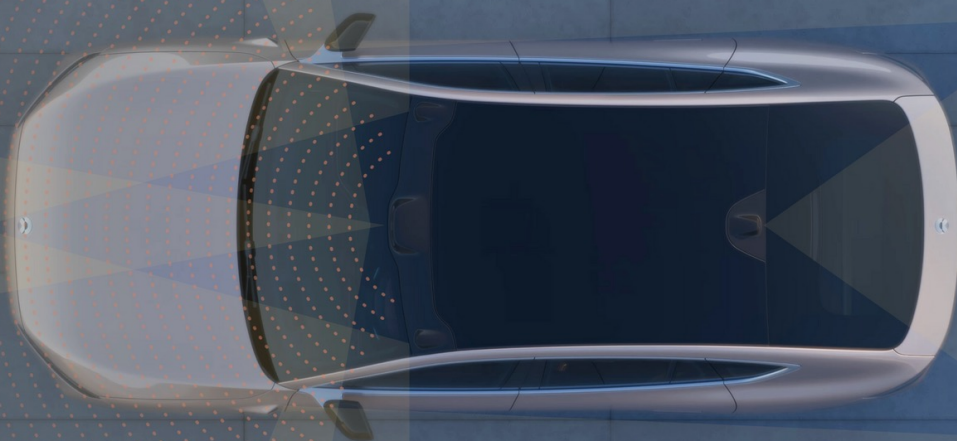

# ADAM

蔚来超算平台 NIO SUPER COMPUTING



## 1,016 TOPS

4 x NVIDIA DRIVE Orin

48  
A78 CPU Cores

256  
3rd Gen Tensor Cores

8,096  
CUDA Cores

68 Billion  
Transistors

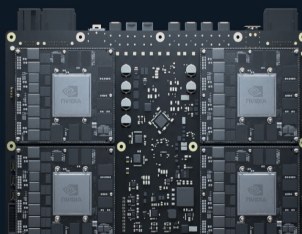

主控一  
MASTER I

冗余备份  
REDUNDANCY

主控二  
MASTER II

群体智能与个性训练  
CROWD AI & PERSONALIZATION

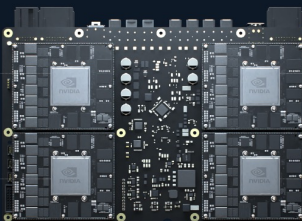



# AQUILA

33个高性能感知硬件 High Performance Sensing Units

11

800万像素高清摄像头  
8MP Camera

1

超远距高精度激光雷达  
1,550nm LiDAR

5

毫米波雷达  
mmWave Radar

12

超声波传感器  
USS

2

高精度定位单元  
GPS + IMU

1

车路协同感知  
V2X

1

增强主驾感知  
ADMS

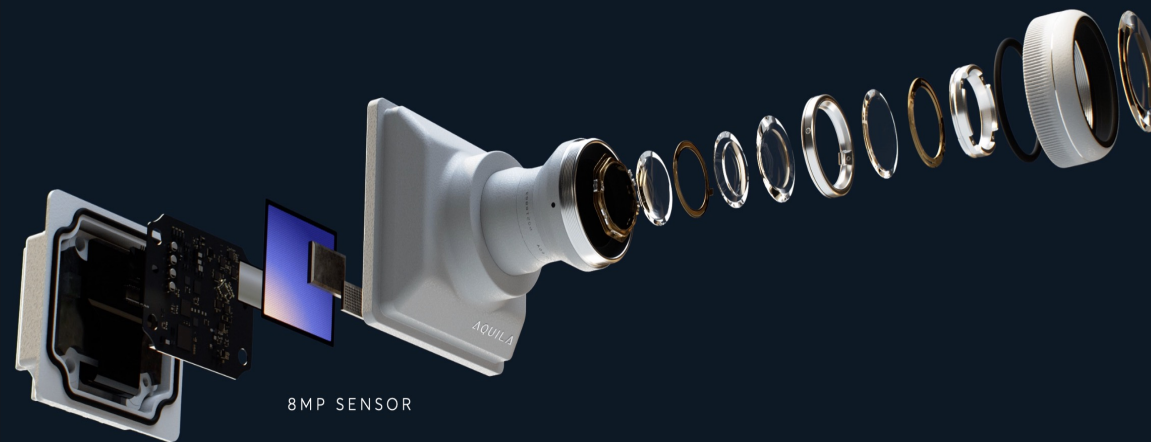

# Software Defined Vehicle





## New Vehicle Models are Developed at a Much Faster Pace

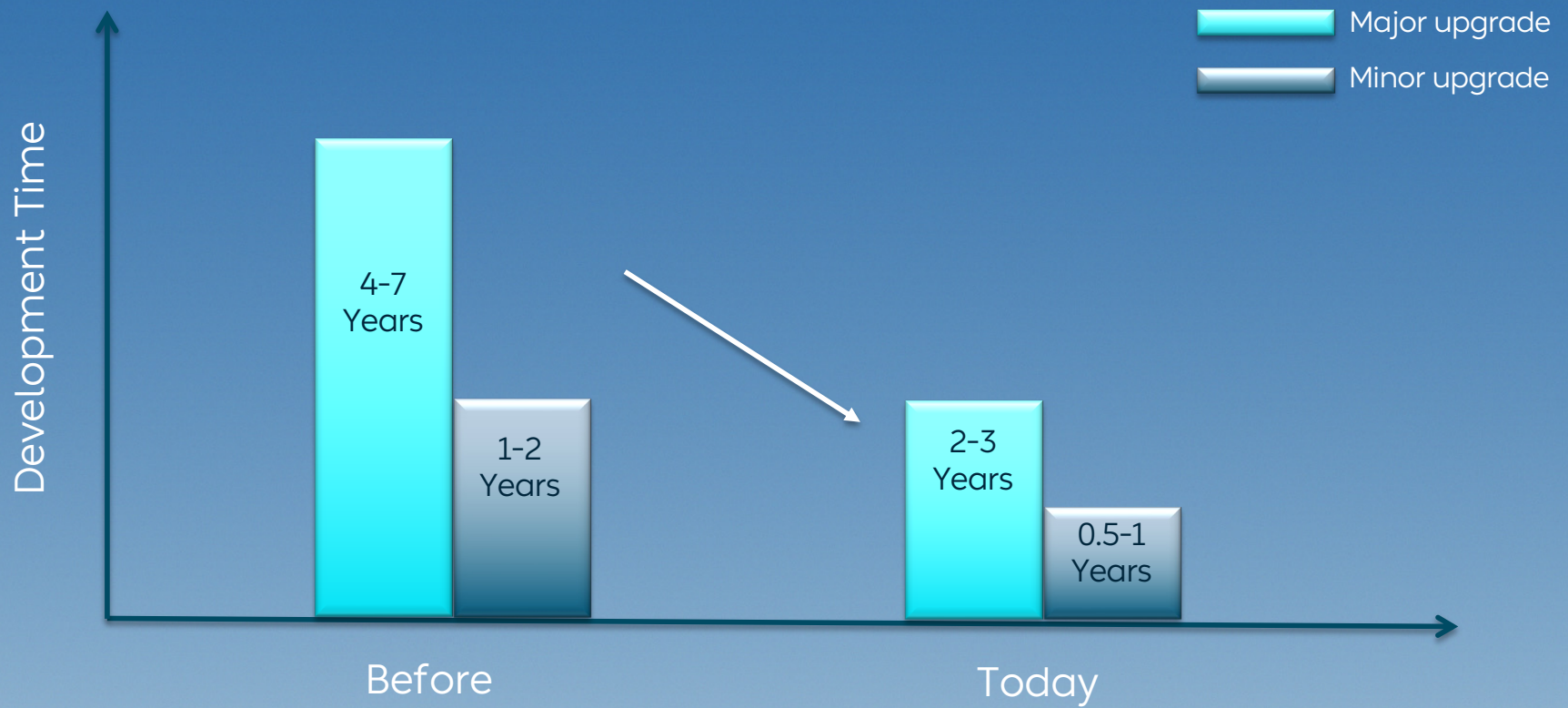

# Continuous Software Upgrade via OTA throughout Vehicle's Lifecycle



头条 @佐思汽车研究



# Evolution of Digital Architecture for Smart Vehicles

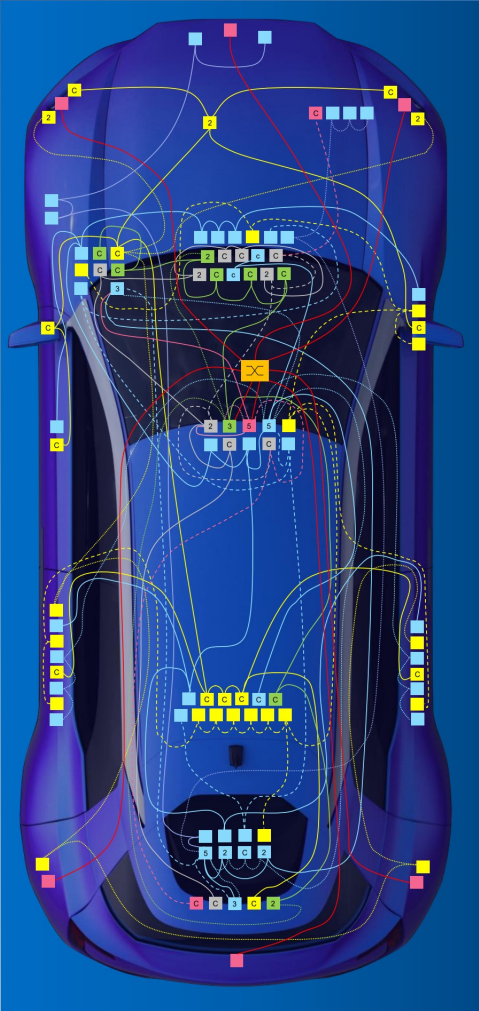

Centralized  
Layered  
Modularized  
Configurable

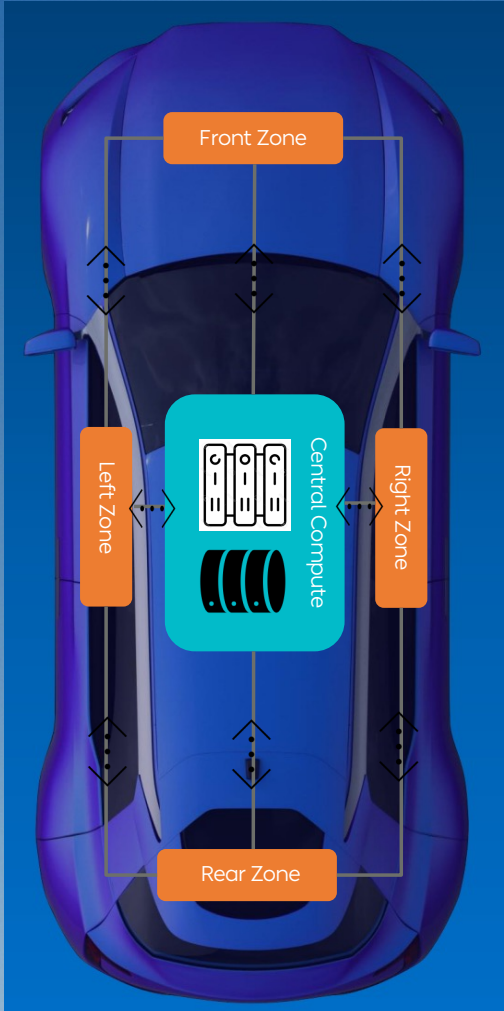

# Automotive SW Development Environment

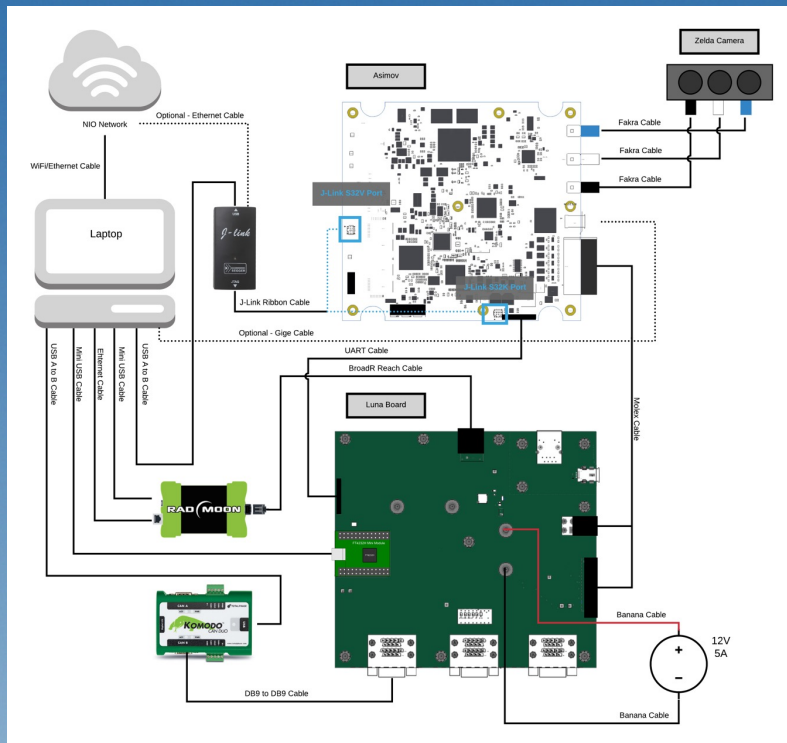

Used to be

Decoupled SW/HW  
Simulation

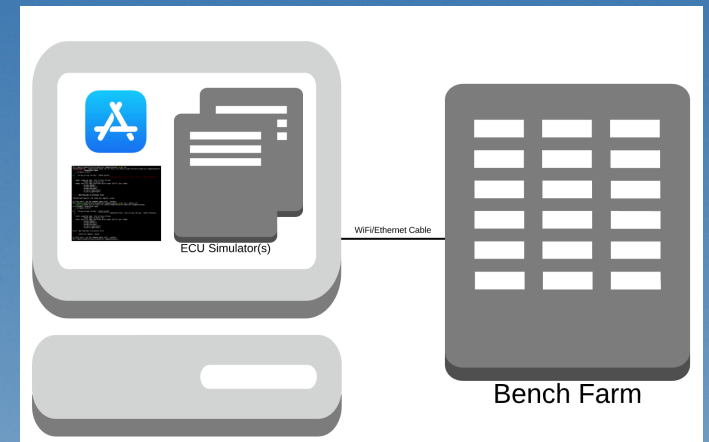

Becoming



# NIO's Digital Architecture for Software Defined Vehicles

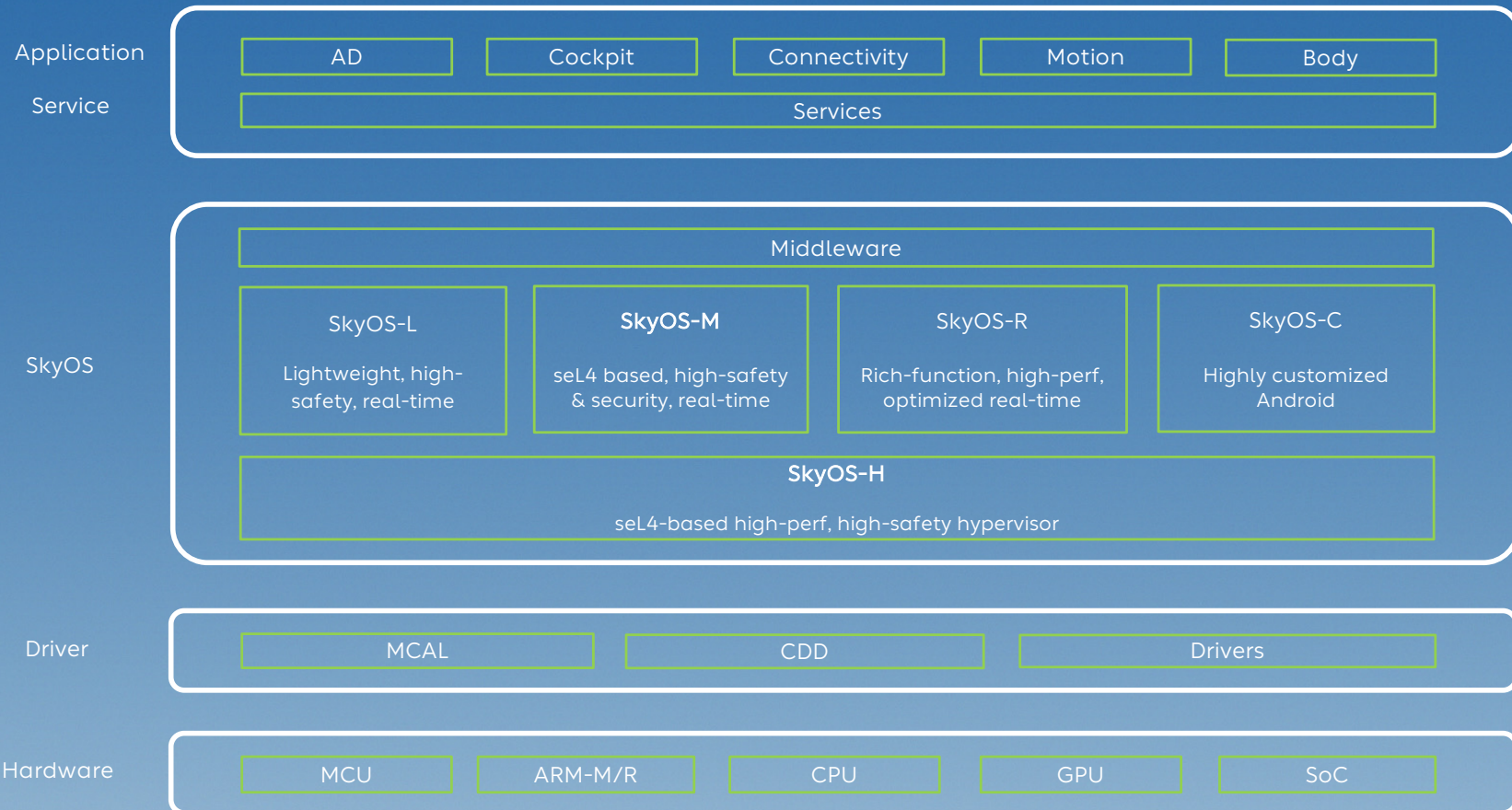

# SkyOS-M based on seL4





## NIO USA Is Actively Hiring

- OS Kernel Developer - NIO Vehicle Operating System (NVOS)
- Software Engineer in TEST - Embedded Systems
- Simulation Engineer - QEMU



NIO swags available at the booth!



NIO

<https://www.nio.com/careers>

Thank you!



Embrace a New Era of Premium Smart EV!